

GROUND LUG:

WIRE RANGE - TWO 350MCM-4  
TIGHTENING TORQUE 375 IN-LB.

L1 L2 L3 T1 T2 T3

CUSTOMER CONNECTIONS:

WIRE RANGE - TWO 350MCM-4  
TIGHTENING TORQUE 375 IN-LB.

Notes:

1. Customer is responsible for installation to meet all national and local electrical codes.
2. Use only hubs or fittings that comply with UL514B for type 3R enclosures.
3. Approx. WT LBS : 800
4. Enclosure Color: RAL 7006 Beige Grey
5. PQconnect Programming Model: Custom Unit HGP0250AWxC1xxx
6. JCI P/N: 371-09214-001

UNIT SPECIFICATIONS						
KVAR	HARMONIC	VOLT	Hz	PHASE	HP	AMPS
75	5TH	480	60	3	250	302

SCHEMATIC : 29597-PQ6

Top View

Customer Wire Entry  
And Exit Location  
If Unused, Customer  
Recommended To Caulk  
Edges Of Close Plate

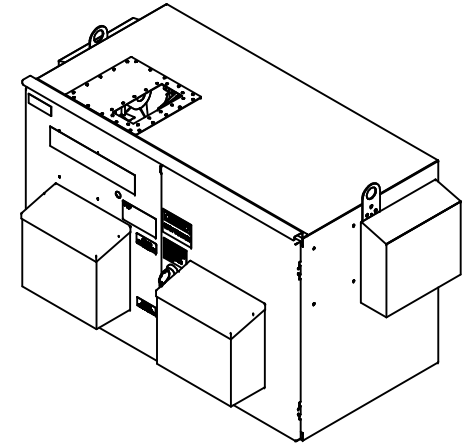
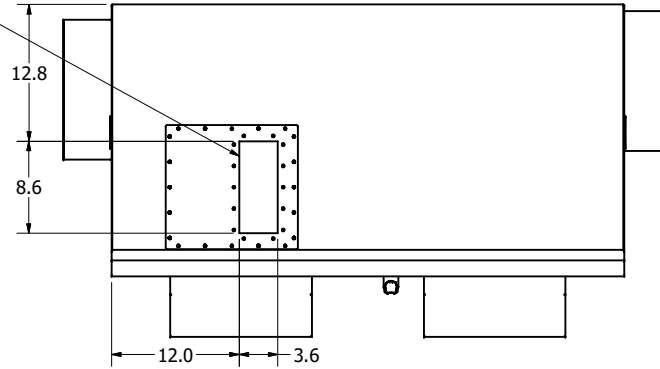

Front View  
Without Doors

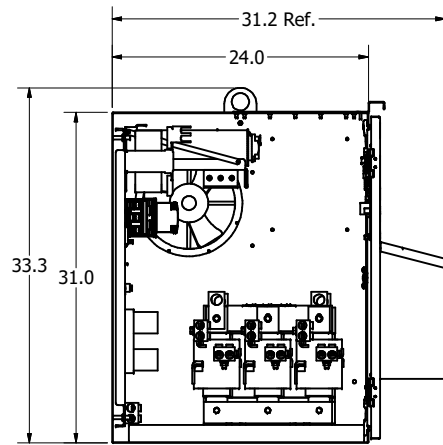
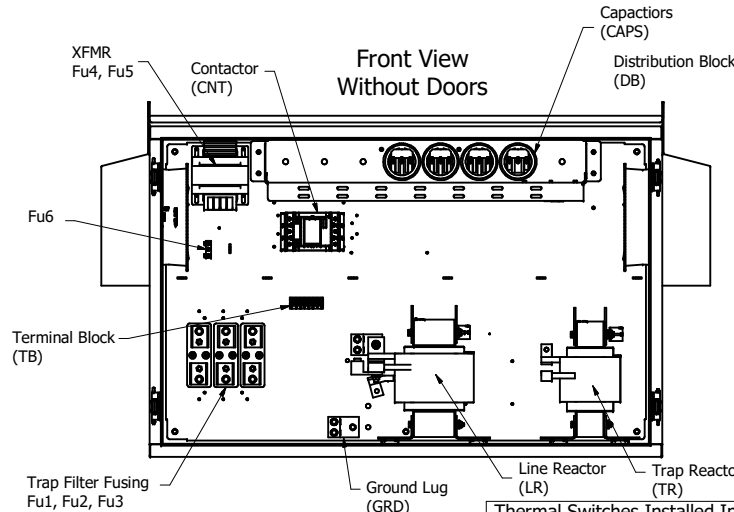

Side View  
Without Wall

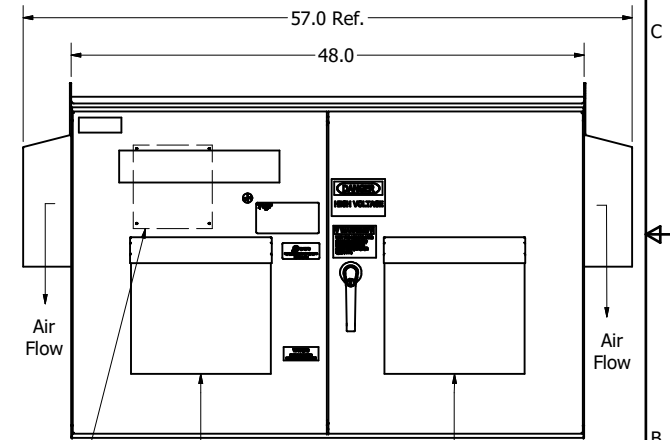

Front View

Thermal Switches Installed In  
Line Reactor And Tuning Reactor  
Wired To PQconnect For Monitoring

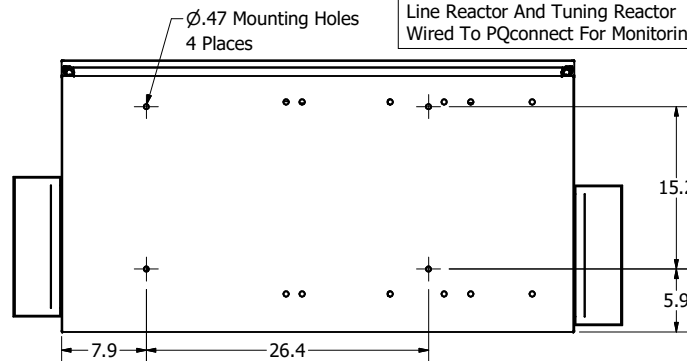

Bottom View

PQconnect Contactor  
Control Board Mounted To  
Inside Of Door

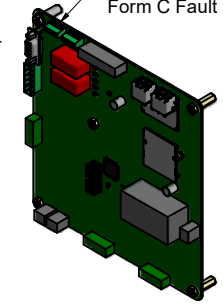

Customer Connection  
Form C Fault Relay J10

THE INFORMATION AND DESIGNS CONTAINED IN THIS DRAWING ARE CONFIDENTIAL AND THE PROPRIETARY PROPERTY OF ALLIED MOTION TECHNOLOGIES INC. AND ITS SUBSIDIARIES. NEITHER THIS DESIGN NOR ANY INFORMATION CONTAINED IN THIS DRAWING MAY BE REPRODUCED OR DISCLOSED TO OTHERS WITHOUT THE EXPRESS WRITTEN CONSENT OF ALLIED MOTION TECHNOLOGIES INC. AND ITS SUBSIDIARIES.

NO	REVISION	DATE	BY	SCALE
D	5839-1 CNT Updated	02/10/22	JRN	
C	5781 Cap Bracket Update	11/24/21	JRN	
B	Updated Hoods	06/03/21	JRN	
A	As Designed	08/21/19	JRN	

TOLERANCES  
(EXCEPT AS NOTED)

DECIMAL  
.XX ± .03  
.XXX ± .010

FRACTIONAL  
± 1/32

ANGULAR  
± 1°

**TCL** W132N10611 (Rev 13) Rev 6  
Germanstown, WI 53022  
© 2021 TCL, LLC

Harmonic Guard Passive  
250HP, 480/3/60, Type 3R, JCI, PQconnect

DRN BY: JRN DATE: 08/21/19  
SCALE: 1/9 DRAWN: JRN  
108107DG  
SHT 1 OF 1